

Is there something cool about science, math, engineering, or technology that you want to share with your class and family? Write or draw about it here.

Read about STEM topics other kids find cool at the Kids' Corner on our website.



My STEM Stories™

Solar Energy

Sun Catchers

Featuring GRID Alternatives

How can you use solar energy to solve a challenge you face?



STEM
Reader:

Vocabulary

Term	Definition	A Picture or Simplified Definition
Solar Radiation	Solar radiation is energy given off by the sun.	
Passive Solar Energy	Passive solar energy involves using the sun's energy without any changes to it or the use of mechanical devices.	
Active Solar Energy	Active solar energy involves using the sun's energy by changing it with a second process or machine.	
Solar Thermal Energy	Solar thermal energy involves specifically using the sun's heat to warm things up.	
Solar Electric Energy	Solar electric energy (also known as solar photovoltaic) is turning sunlight into electrical energy.	
Circuit	A circuit is a path or route for electrons/electricity that will start and return to the same place.	
Watt	A watt is a unit of power—the amount of energy that is transferred in a second.	

Renewable Energy

Increasing pressure to seek alternative energy sources has generated new business opportunities and scientific study. Scientists, engineers, and entrepreneurs alike are interested in how to sustainably harvest our renewable resources—sun, wind, geothermal, tides, rivers, etc.

Solar power involves harnessing energy from the sun's light. This can be done in two ways: either as passive solar thermal or as active solar power. Passive solar thermal uses the heat from the sun's light to increase the temperature of a place or object. Active solar power uses the sun's light or heat in one place to deliver electricity or heat to another place.



Hydropower is energy generated from the energy of falling water or running water. For example, a large dam that is placed in a river forces the water to flow over or through the dam. The falling water has a lot of energy and when it passes through the dam's turbines it generates electricity.

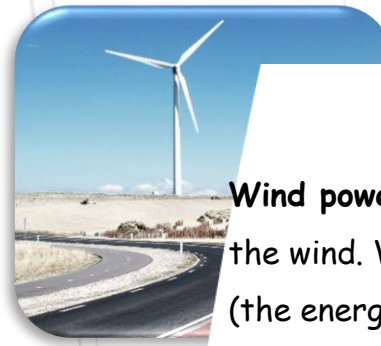

Wind power uses the energy in the movement of the wind. Wind turbines convert the kinetic energy (the energy of motion) of the wind into mechanical power. This mechanical power can be used for specific tasks (such as grinding grain or pumping water), or it can be converted into electricity to power things like homes, businesses, and schools.

Geothermal energy is heat from Earth. It comes from many places: volcanos, hot water springs, and more. In the United States a lot of the geothermal energy comes from the top 10 feet of ground, that stays between 50°F and 60°F year-round. Heat exchangers use the heat difference between the ground and a home to heat the home in the winter and cool it in the summer.



As we develop new source of energy, there is a need for improved materials and better processes for energy capture and storage. These needs are a source of endless opportunity for new discoveries and inventions.



What kind of energy would you use and why if you lived in the following places?

Near a large waterfall.

Near a volcano.

In a city with very little rain.

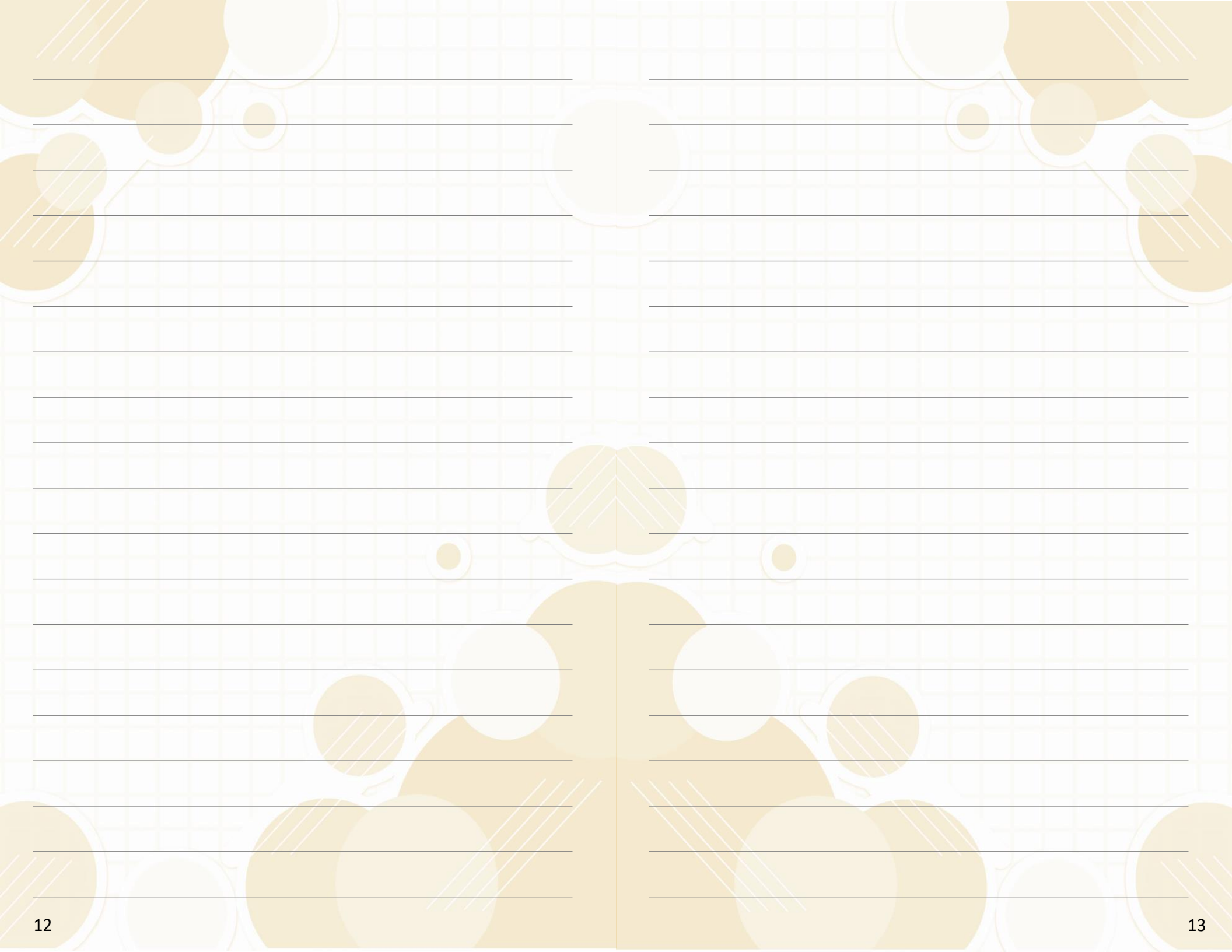

Create Your Own Timeline



20?? CE

What will
you invent?

Meet Erica Mackie: Co-Founder and CEO of GRID Alternatives



Erica Mackie, PE, is the co-founder and CEO of GRID Alternatives. We asked her to talk a bit about herself and about the solar electricity company she started with Tim Sears.

How would you describe yourself and your career path?

"I think of myself as a social worker turned engineer then turned back to something in between. My path to clean energy included work with survivors of domestic violence, at-risk youth, women's studies, outdoor education, math, and physics. I am an entrepreneur because in the end, in order to have the job and impact I dreamed of having, I needed to create it."

How did you get the idea for GRID Alternatives?

"In 2001, I was working as a professional engineer implementing large-scale renewable energy and energy efficiency projects for the private sector. It was at this job that Tim Sears and I met and thought of the idea for GRID Alternatives. It took us a few years to actually quit our jobs and decide to start our own nonprofit business, but that time we took to create a joint vision and establish a collaborative leadership style has been critical to our success today."

How would you describe GRID Alternatives?

GRID Alternatives is a national leader in making clean, affordable solar power and solar jobs accessible to all communities. By putting people first, GRID Alternatives develops and implements solar projects that serve qualifying households and affordable housing providers and offers solar education and hands-on job training to help people jumpstart their solar careers.

Meet Erica Mackie: Co-Founder and CEO of GRID Alternatives

How has GRID Alternatives grown over the years?

"GRID Alternatives has grown a lot over the years. We started out with the idea of installing solar for low-income homeowners with volunteers, like Habitat for Humanity except with solar.

As we grew, we kept finding more community needs and opportunities to do more. Today we have a staff of 350 around the United States, and we're installing 1,500 solar electric systems a year, mostly for homeowners but also for renters, affordable housing buildings, and even some community organizations that have goals that are similar to ours.

We also do work in Nicaragua, Nepal, and Mexico for communities that either have no access to electricity or for which access is expensive and unreliable. We also train people. We found that many people were volunteering with us because they wanted work experience for jobs in solar, so we started to build out a real workforce development program. We've trained over 35,000 people, both volunteers and solar career aspirants, in solar installation."

What do you think it take to be a successful entrepreneur?

"Being a successful entrepreneur, whether in the nonprofit sector or in business, is about more than just that initial vision. It's also about being able to adapt and grow as the environment changes and opportunities arise. With a new technology like solar, there's so much opportunity and so much need, and we'll keep working and innovating until we're not needed anymore."



Erica states that one of the reasons GRID Alternatives has been successful is because of their vision and collaborative leadership style. What do you think she means by that?

What are some examples of collaborations that she describes?



The team at GRID Alternatives is always keeping their eyes open for new things they can do to help people. What are two things they are doing now that you think they were not doing when they started the company, and what makes you think they weren't doing them when they started?

Meet Laura Stachel: Co-Founder of We Care Solar

ABOUT LAURA

Laura studied medicine and lives in California. In 2008 she went to Northern Nigeria to try to figure out ways to make having a baby safer for moms and babies. When she was there, she saw that most hospitals didn't have a reliable and constant source of electricity! While this made things hard during the day, it made having a baby at night very dangerous. Sometimes babies were born in total darkness. Other times mothers and babies had to wait hours for important surgery.

FOUNDATIONAL SCIENCE

Solar electric (also known as solar photovoltaic) is the action of turning sunlight into electrical energy. This is done with solar cells that are made of materials called SEMICONDUCTORS that have special properties. Semiconductors are a mix between a conductor (like metal) and an insulator (like rubber). When sunlight hits a semiconductor,

some of the electrons get pushed out (like too many people sitting on a bench) and they flow through the wires making electricity.

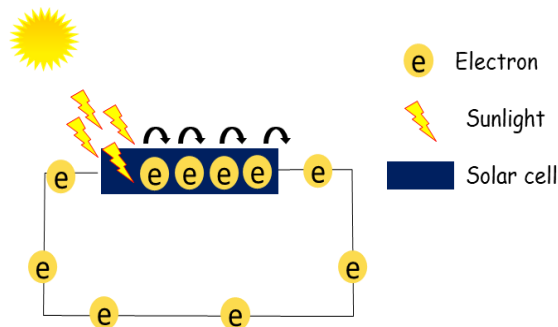

Photo of Laura Stachel from We Care Solar Used with permission

GAME-CHANGING IDEA

When she got home from Nigeria, Laura joined forces with Hal Aronson, and together they started We Care Solar to help provide hospitals with reliable electricity. Hal created a suitcase-sized solar electric system, which included solar panels, batteries, LED lights, and headlamps, for Laura to show to the Nigerian hospital workers. When Laura returned to Nigeria with the "solar suitcase," her Nigerian colleagues were very excited that everything they needed to bring light and electricity to their clinics was contained in an easy-to-use suitcase. They began using the kit to charge headlamps and walkie-talkies immediately! To date We Care Solar and their partners have distributed almost 3,000 Solar Suitcases around the world.

Useful Phrases for Having Constructive Discussions

Asking Clarifying Questions

Can you be more specific?

Can you explain your answer further?

Can you give an example?

Can you please explain your thinking?

Can you repeat what you said?

Could you rephrase that?

Could you say that one more time?

What is your evidence?

Can you give me another example, so I can understand?

Can you tell me more?

Why do you think that is important?

Why do you think that happened?

What if the opposite were true?

Adding to an Idea

I agree with _____ because _____.

I agree with _____.

I agree with _____ and I also think _____.

I agree with _____ and would like to add _____.

I agree, and I have an addition: _____.

I believe this is true because _____.

I know that too because _____.

I have something to add; _____.

I think you are right, and I also think _____.

I would like to add to that idea.

This reminds me of _____ because _____.

Yes, that makes sense, and I would also like to add _____.

Respectfully Disagreeing with an Idea

Could you explain, because I have a different idea.

I disagree with that idea because _____.

I disagree with your reasoning because _____.

I disagree with _____ because _____.

I have completely different opinion on that.

I respect your opinion and _____.

I respect your point, and in my opinion _____.

I respectfully disagree because _____.

I see your reasoning and disagree with some of the idea because _____.

That's a good point, and _____.